

产品介绍

GRIP-R

折叠式管道修补器

折叠式管道连接修补器，可在不更换管道的情况下，对老化锈蚀、管壁出现沙眼或裂缝泄露的管道进行修补。

安装时，只需将管道连接器包好泄露部位、收紧螺栓，便可理想而又可靠地完成安装工作。

折叠式管道连接修补器适用于管道外径范围为：26.9mm~168.3mm。



外形图示

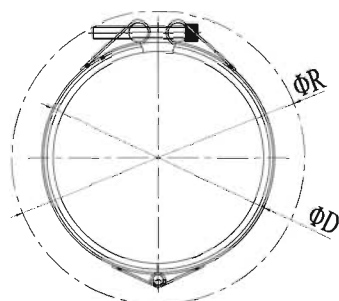
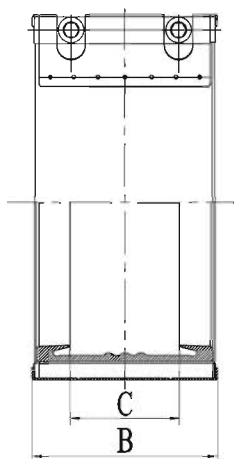

组件	材质	V1	V2	V3	V4	V5	V6
外壳		AISI 304	AISI 316L	AISI 316Ti	AISI 316L	AISI 316Ti	
螺栓		AISI 304	AISI 316L	AISI 316L	AISI 304	AISI 304	
插销		AISI 304	AISI 316L	AISI 316L	AISI 304	AISI 304	
齿环							
钢夹片 (可选)		AISI 301	AISI 301	AISI 301	AISI 301	AISI 301	

备注：

- 1: 钢夹片可根据客户需求定制 AISI 316L/316Ti
- 2: 其他特殊要求请联系北京吉瑞普

产品介绍

GRIP-R

管道外径		适用范围	工作压力		产品外径	产品宽度	密封层之间的 距离	安装时管端间距		扭力值	螺栓
O.D.	Min-Max			Φ D	B	C	不加 钢夹片	加 钢夹片	Max (mm)	(Nm)	M
(mm)	(in.)	(mm)	(bar)	(bar)	(mm)	(mm)	(mm)	(mm)			
26.9	1.059	26-28	25	40	38	57	30	5-8	10	8	
30	1.181	29-31	25	40	42	57	30	5-8	10	8	M6×2
33.7	1.327	32-35	25	40	45	57	30	5-8	10	8	
38	1.496	37-39	25	40	50.3	61	26	5-8	10	10	
42.4	1.669	41-43	25	40	54.7	61	26	5-8	10	10	M8×1
44.5	1.752	44-46	25	40	56.8	61	26	5-8	10	10	
48.3	1.902	47-50	25	40	64.2	61	26	5-8	10	10	
54	2.126	52-56	20	35	70	76	37	5-10	15	10	
57	2.244	55-59	20	35	73	76	37	5-10	15	10	M8×2
60.3	2.374	59-62	20	35	76.2	76	37	5-10	15	10	
66.6	2.622	64-68	20	40	85.5	95	37	5-10	25	20	
70	2.756	68-71	20	40	89	95	41	5-10	25	20	
73	2.874	71-75	20	40	92	95	41	5-10	25	20	
76.1	2.996	74-78	20	40	95.2	95	41	5-10	25	20	
79.5	3.130	78-80	20	40	98.5	95	41	5-10	25	20	
84	3.307	82-86	20	40	103	95	41	5-10	25	20	
88.9	3.500	87-91	20	40	108	95	41	5-10	25	20	M8×2
100.6	3.961	99-103	18	35	120	95	41	5-10	25	20	
101.6	4.000	100-104	18	35	120.7	95	41	5-10	25	20	
104	4.094	102-106	18	35	123	95	41	5-10	25	20	
104.8	4.126	103-107	18	35	124	95	41	5-10	25	20	
108	4.252	106-110	18	35	127	95	41	5-10	25	20	
114.3	4.500	112-116	18	35	133.4	95	54	5-10	25	20	
127	5.000	125-129	18	40	148	110	54	5-10	35	25	
129	5.079	127-131	18	40	150	110	54	5-10	35	25	
130.2	5.126	128-132	18	40	151.3	110	54	5-10	35	25	
133	5.236	131-135	18	40	154	110	54	5-10	35	25	
139.7	5.500	138-142	18	40	160.8	110	54	5-10	35	25	M12×2
141.3	5.563	139-143	18	35	162.4	110	54	5-10	35	25	
154	6.063	152-156	18	35	173.4	110	54	5-10	35	25	
159	6.260	157-161	18	35	180	110	54	5-10	35	25	
168.3	6.626	166-171	18	35	186	110	54	5-10	35	25	

备注：

如有特殊规格要求，请联系吉瑞普定做。

 海事船舶应用领域的工作压力，测试压力为 4 倍的工作压力。

 工业和陆用领域的工作压力，测试压力为 1.5 倍的工作压力。

可能出现输入错误，技术细节可能随着产品的不断更新改进而有所变化。下单前请和北京吉瑞普最终确认。